

Pallet truck scale *HLS-GC*



Funktionen & Merkmale

- ▶ TÜV, CE and GS certified industrial quality
- ▶ Capacity up to 2500 kg
- ▶ Readability 500 g, optionally 200 g
- ▶ Easy-grip pump and drawbar
- ▶ Rubberized tiller handle with 3 functions: raise- drive- sink
- ▶ Drawbar with extra reinforcement for the shear
- ▶ Extremely robust, agile and silent
- ▶ Sturdy, powder-coated construction with four high-quality load cells
- ▶ Overload protection - extra pressure relief valve, therefore long service life
- ▶ Fast lift as standard with sensitive lowering
- ▶ Rounded fork tips with entry rollers for easy pickup of pallets (also crosswise)
- ▶ Maintenance-free, airtight and dustproof high performance hydraulic pump made of high strength steel
- ▶ Resilient hard rubber - tandem roller
- ▶ Optional integrated thermal printer with freely configurable print formats
- ▶ Accuracy class III
- ▶ Counting indicator GTC in two housing variants (Plastics IP 54 or Aluminium IP 65)
- ▶ Basic functions: Tare across 100 % of weighing range, zero, gross/net, manual tare
- ▶ Totalisation of weights and quantities
- ▶ Variable reference quantity with reference updating to optimise the counting accuracy
- ▶ Three illuminated displays - weight, piece weight and quantity
- ▶ Audible signal when a target quantity is exceeded
- ▶ Numeric keypad for entering piece weights, tare weights and target quantities
- ▶ Intuitive operation, sturdy foil keypad
- ▶ Various interfaces for connecting printer, hand scanner or PC
- ▶ Alibi memory with date and time
- ▶ By default, the indicator is powered via an AC adapter or the internal battery

Pallet truck scale *HLS GC*

Pallet truck scale HLS-GC

The pallet truck with integrated counting Scale is the ideal solution for quick and easy weighing and counting at different locations. Especially in logistics, the pallet truck scale is advantageous. The pallet trucks with scale are simple in use and handling. It is no longer necessary to remove the pallet from the pallet truck to weigh. Just pump up and read off the weight.

Konstruktion

For extra sturdiness and stability is the powder-coated steel frame reinforced and impact-proof. The frame features a built-in compact hydraulic unit encased in an impact-proof steel housing. With a total capacity of 2500 kg, and a division of 500 g, a precisely weight detection is guaranteed at any height.

Weighing technology

As data is displayed on 3 LCD displays, the operator has all the most important information available at a glance. The adjustable

backlight guarantees an optimal readability, even with unfavorable light conditions. An intuitive operation via the comfortable foil keypad with 22 keys allows even untrained staff an easy handling. Via the numeric keypad it is possible to input reference quantity - piece weight. At check weighing setting limits is therefore very easy.

Power supply and interfaces

The rechargeable battery enables power-independent weighing. The long battery life of approx. 36 hours (20 hours with backlight / 12 hours with WLAN) enables flexible working. Adjustable backlighting and automatic switch-off protect the battery.

Optional accessories

Integrated thermal printer, adapter for a rotatable display, exchangeable battery module including charger, calibration certificate.

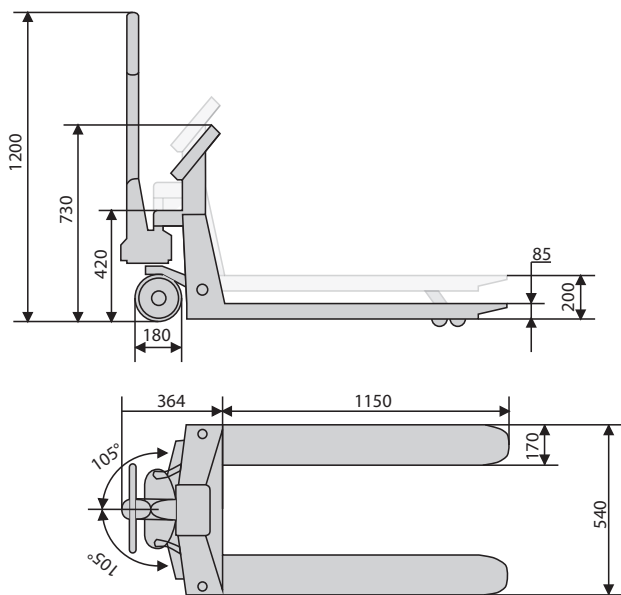

Infeed rollers for easy passage over obstacles. For example for lateral entry of crosswise pallets.

